

V-CYMBAL RIDE **CY-13R**
V-CYMBAL CRASH **CY-12C**

Owner's Manual

Before using this unit, carefully read the sections entitled: **“USING THE UNIT SAFELY”** and **“IMPORTANT NOTES”** (p. 2; p. 3). These sections provide important information concerning the proper operation of the unit. Additionally, in order to feel assured that you have gained a good grasp of every feature provided by your new unit, Owner's manual should be read in its entirety. The manual should be saved and kept on hand as a convenient reference.



USING THE UNIT SAFELY

INSTRUCTIONS FOR THE PREVENTION OF FIRE, ELECTRIC SHOCK, OR INJURY TO PERSONS

About ⚠️ WARNING and ⚠️ CAUTION Notices

⚠️ WARNING	Used for instructions intended to alert the user to the risk of death or severe injury should the unit be used improperly.
⚠️ CAUTION	Used for instructions intended to alert the user to the risk of injury or material damage should the unit be used improperly. * Material damage refers to damage or other adverse effects caused with respect to the home and all its furnishings, as well to domestic animals or pets.

About the Symbols

	The ⚠️ symbol alerts the user to important instructions or warnings. The specific meaning of the symbol is determined by the design contained within the triangle. In the case of the symbol at left, it is used for general cautions, warnings, or alerts to danger.
	The symbol alerts the user to items that must never be carried out (are forbidden). The specific thing that must not be done is indicated by the design contained within the circle. In the case of the symbol at left, it means that the unit must never be disassembled.
	The symbol alerts the user to things that must be carried out. The specific thing that must be done is indicated by the design contained within the circle. In the case of the symbol at left, it means that the power-cord plug must be unplugged from the outlet.

ALWAYS OBSERVE THE FOLLOWING

WARNING

- Do not open or perform any internal modifications on the unit.
- Do not attempt to repair the unit, or replace parts within it (except when this manual provides specific instructions directing you to do so). Refer all servicing to your retailer, the nearest Roland Service Center, or an authorized Roland distributor, as listed on the "Information" page.
- Never install the unit in any of the following locations.
 - Subject to temperature extremes (e.g., direct sunlight in an enclosed vehicle, near a heating duct, on top of heat-generating equipment); or are
 - Damp (e.g., baths, washrooms, on wet floors); or are
 - Exposed to steam or smoke; or are
 - Subject to salt exposure; or are
 - Humid; or are
 - Exposed to rain; or are
 - Dusty or sandy; or are
 - Subject to high levels of vibration and shakiness.

- This unit should be used only with a stand (MDS series) that is recommended by Roland.
- When using the unit with a stand (MDS series) recommended by Roland, the stand (MDS series) must be carefully placed so it is level and sure to remain stable. If not using a stand (MDS series), you still need to make sure that any location you choose for placing the unit provides a level surface that will properly support the unit, and keep it from wobbling.

WARNING

- Never allow foreign objects (e.g., flammable objects, coins, wires) or liquids (e.g., water or juice) to enter this product. Doing so may cause short circuits, faulty operation, or other malfunctions.
- In households with small children, an adult should provide supervision until the child is capable of following all the rules essential for the safe operation of the unit.
- Protect the unit from strong impact. (Do not drop it!)

CAUTION

- Try to prevent cords and cables from becoming entangled. Also, all cords and cables should be placed so they are out of the reach of children.
- Never climb on top of, nor place heavy objects on the unit.
- Should you remove the stopper bolt, keep them in a safe place out of children's reach, so there is no chance of them being swallowed accidentally.

IMPORTANT NOTES

Placement

- Do not expose the unit to direct sunlight, place it near devices that radiate heat, leave it inside an enclosed vehicle, or otherwise subject it to temperature extremes. Excessive heat can deform or discolor the unit.
- When moved from one location to another where the temperature and/or humidity is very different, water droplets (condensation) may form inside the unit. Damage or malfunction may result if you attempt to use the unit in this condition. Therefore, before using the unit, you must allow it to stand for several hours, until the condensation has completely evaporated.
- Do not allow rubber, vinyl, or similar materials to remain on this unit for long periods of time. Such objects can discolor or otherwise harmfully affect the finish.

Maintenance

- For everyday cleaning wipe the unit with a soft, dry cloth or one that has been slightly dampened with water. To remove stubborn dirt, use a cloth impregnated with a mild, non-abrasive detergent. Afterwards, be sure to wipe the unit thoroughly with a soft, dry cloth.
- Never use benzine, thinners, alcohol or solvents of any kind, to avoid the possibility of discoloration and/or deformation.

Additional Precautions

- Use a reasonable amount of care when using the output jacks. Rough handling can lead to malfunctions.
- When connecting / disconnecting all cables, grasp the connector itself—never pull on the cable. This way you will avoid causing shorts, or damage to the cable's internal elements.
- To avoid disturbing your neighbors, try to keep the unit's volume at reasonable levels. You may prefer to use headphones, so you do

not need to be concerned about those around you.





- This instrument is designed to minimize the extraneous sounds produced when it's played. However, since sound vibrations can be transmitted through floors and walls to a greater degree than expected, take care not to allow these sounds to become a nuisance to neighbors, especially when using headphones.
- When you need to transport the unit, package it in the box (including padding) that it came in, if possible. Otherwise, you will need to use equivalent packaging materials.
- The rubber portion of the striking surface is treated with a preservative to maintain its performance. With the passage of time, this preservative may appear on the surface as a white stain, or reveal how the pads were struck during product testing. This does not affect the performance or functionality of the product, and you may continue using it with confidence.
- Continuous playing may cause dis-coloration of the pad, but this will not affect the Pad's function.
- Roland, V-Drums, and V-CYMBALS are registered trademarks of Roland Corporation in the United States and/or other countries.

• All product names mentioned in this document are trademarks or registered trademarks of their respective owners.





Getting Started

What's in the Package

CY-13R (Ride)

- CY-13R Cymbal pad
- Wing nut 
- Felt washer 
- Stopper 
- Connection cable (stereo) x 2
- Cable tie 
- Owner's manual (this document)

CY-12C (Crash)

- CY-12C Cymbal pad
- Wing nut 
- Felt washer 
- Stopper 
- Connection cable (stereo)
- Cable tie 
- Owner's manual (this document)

Definitions & Names of Parts

CY-13R

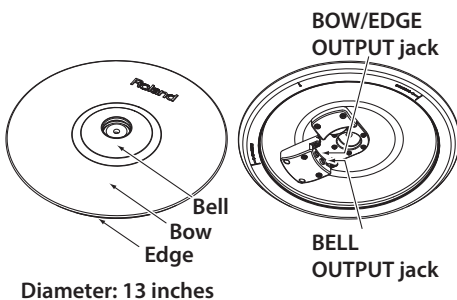

Diameter: 13 inches

* The CY-13R is not capable of detecting the striking position. If you're using a Roland percussion sound module that is capable of detecting the striking position, you'll need to set the ride's Position Ctrl to OFF. For details on how to make the setting, refer to the owner's manual that came with your percussion sound module.

CY-12C

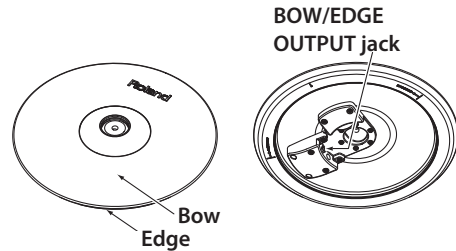

* The CY-12C has no BOW/BELL OUTPUT jack.

Diameter: 12 inches

Main Specifications

CY-13R (Ride)

Size	13 inches
Trigger	3 (Bow/Bell/Edge)
Connectors	BELL OUTPUT jack, BOW/EDGE OUTPUT jack
Dimensions	331 (W) x 331 (D) x 48 (H) mm 13-1/16 (W) x 13-1/16 (D) x 1-15/16 (H) inches
Weight	1.1 kg / 2 lbs 7 oz
Accessories	Owner's manual, Wing nut, Felt washer, Stopper, Connection cable (stereo) x 2, Cable tie
Options	Cymbal mount (MDY series) Cymbal parts set (CYM-10) Drum stands (MDS series)

CY-12C (Crash)

Size	12 inches
Trigger	2 (Bow/Edge)
Connectors	BOW/EDGE OUTPUT jack
Dimensions	305 (W) x 305 (D) x 45 (H) mm 12-1/16 (W) x 12-1/16 (D) x 1-13/16 (H) inches
Weight	940 g / 2 lbs 2 oz
Accessories	Owner's manual, Wing nut, Felt washer, Stopper, Connection cable (stereo), Cable tie
Options	Cymbal mount (MDY series) Cymbal parts set (CYM-10) Drum stands (MDS series)

* In the interest of product improvement, the specifications and/or appearance of this unit are subject to change without prior notice.

Making the Settings

Mounting on the Stand

1. Use a commercially available drum key to tighten the stopper bolt.

The stopper keeps the V-Cymbal from turning, preventing the tangling of cables on the stand.

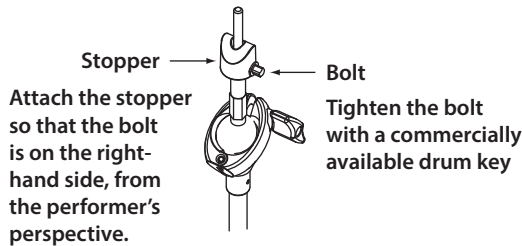

2. Attach the V-Cymbal, while positioning it so the Roland logo is located on the side opposite the performer.

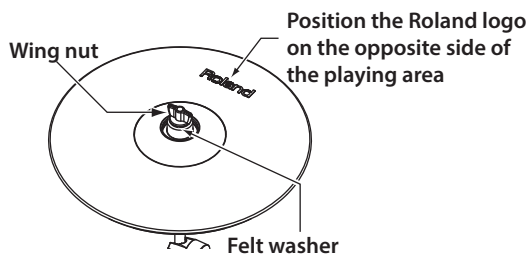

3. Tighten the included felt washer and the wing nut to obtain the desired movement.

- * Use the included felt washer and wing nut.
- * Double sounding may occur if the wing nut is loose.

4. Secure the cables in place with the cable tie, and leave some slack in the cables to ensure they are not pulled by the movement of the V-Cymbal pads.

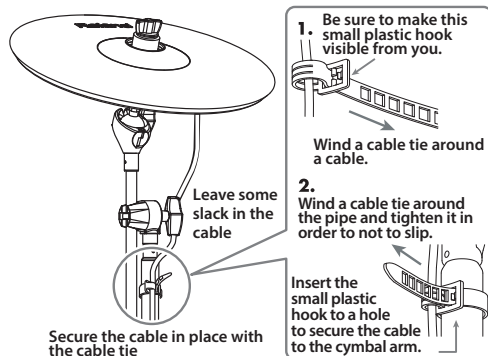

- * Take care to ensure that the cables do not touch the V-Cymbal pads and/or the stand. A cable touching a V-Cymbal pad or a stand may cause double sounding or other incorrect operation.

Connecting to a Percussion Sound Module

- * To prevent malfunction and/or damage to speakers or other devices, always turn down the volume, and turn off the power on all devices before making any connections.
- * Use the supplied connection cables (stereo) to make the connections. If monaural cables are used, edge shots, bell shots, and choke play cannot be supported.

Connect the L-shaped plug of the included cable to the CY-13R/12C.

The CY-12C has no BELL OUTPUT jack. Make the connection to the BOW/EDGE OUTPUT jack.

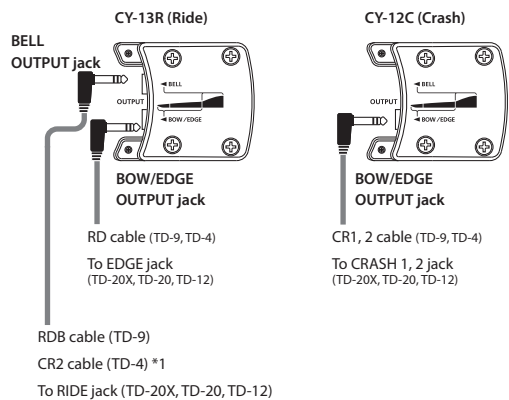

*1 Set the Crash 2 Usage parameter to "RIDE BELL."

About three-way triggering (CY-13R only)

The CY-13R can take advantage of your percussion sound module's three-way triggering functionality to allow you to play bow, bell, and edge separately.

Connect the two outputs BOW/BELL and BOW/EDGE to the percussion sound module at the same time.

For details on the connection method and settings, refer to the owner's manual for your percussion sound module.

- * If you won't be using the three-way triggering functionality, connect the BOW/EDGE OUTPUT jack (not both) to your percussion sound module.
- * Although you'll be able to play using the bow and bell sections when connected to the BELL OUTPUT jack, you won't be able to use the choking technique.

Playing Methods

Bow Shot

This is the most common playing method, playing the middle area of the cymbal.

It corresponds to the sound of the **“head-side”** of the connected trigger input.

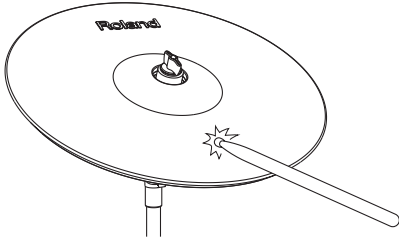

Edge Shot

This playing method involves striking the edge with the shoulder of the stick.

When played as shown in the figure, the **“rim-side”** sound of the connected input is triggered.

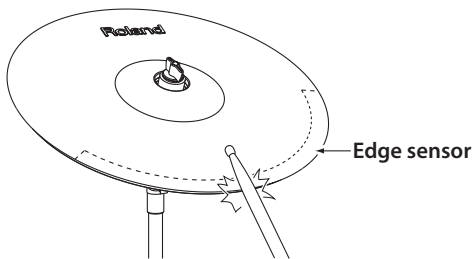

* On the CY-13R, edge shots are possible when the connection is made to the BOW/EDGE OUTPUT jack.

Bell Shot (CY-13R Only)

This playing method involves striking the bell.

On the CY-13R, when played as shown in the figure, the **“rim-side”** sound of the connected input is triggered.

Strike the bell somewhat strongly with the shoulder of the stick.

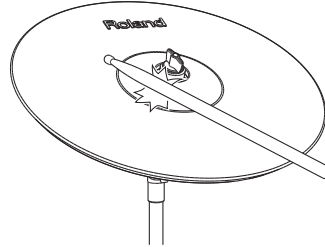

* Bell shots are possible when the connection is made to the CY-13R's BELL output.

* On the CY-12C, bell shots are not supported.

Choke Play

Choking (pinching) the cymbal's edge with the hand immediately after hitting the cymbal makes the sound stop.

Choke the location of the edge sensor shown in the figure. If you choke an area where there is no sensor, the sound does not stop.

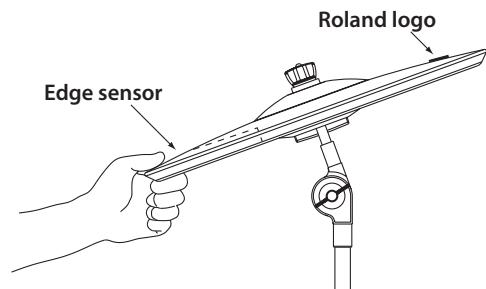

* When ONLY using the BELL output of the CY-13R, the choke function will not work.

Trigger Parameter Settings for the Percussion Sound Module

Recommended Settings for the Trigger Parameters

These are the recommended trigger parameter settings when using the V-Cymbal with various models of sound module. You may need to adjust the trigger parameters depending on how you've attached the V-Cymbal and the location at which you've installed it.

* In order to use three-way triggering with the CY-13R, you must make settings on your percussion sound module to use its three-way triggering functionality. For details on the procedure, refer to the owner's manual for your percussion sound module.

TD series, SPD-30, SPD-SX, HPD-20

	CY-12C	CY-13R
Trig Type	CY12C	CY13R

HPD-10

	CY-12C	CY-13R
Type	CY-12/14	

For EU Countries



- UK** This symbol indicates that in EU countries, this product must be collected separately from household waste, as defined in each region. Products bearing this symbol must not be discarded together with household waste.
- DE** Dieses Symbol bedeutet, dass dieses Produkt in EU-Ländern getrennt vom Hausmüll gesammelt werden muss gemäß den regionalen Bestimmungen. Mit diesem Symbol gekennzeichnete Produkte dürfen nicht zusammen mit dem Hausmüll entsorgt werden.
- FR** Ce symbole indique que dans les pays de l'Union européenne, ce produit doit être collecté séparément des ordures ménagères selon les directives en vigueur dans chacun de ces pays. Les produits portant ce symbole ne doivent pas être mis au rebut avec les ordures ménagères.
- IT** Questo simbolo indica che nei paesi della Comunità europea questo prodotto deve essere smaltito separatamente dai normali rifiuti domestici, secondo la legislazione in vigore in ciascun paese. I prodotti che riportano questo simbolo non devono essere smaltiti insieme ai rifiuti domestici. Ai sensi dell'art. 13 del D.Lgs. 25 luglio 2005 n. 151.
- ES** Este símbolo indica que en los países de la Unión Europea este producto debe recogerse aparte de los residuos domésticos, tal como está regulado en cada zona. Los productos con este símbolo no se deben depositar con los residuos domésticos.
- PT** Este símbolo indica que nos países da UE, a recolha deste produto deverá ser feita separadamente do lixo doméstico, de acordo com os regulamentos de cada região. Os produtos que apresentem este símbolo não deverão ser eliminados juntamente com o lixo doméstico.
- NL** Dit symbool geeft aan dat in landen van de EU dit product gescheiden van huishoudelijk afval moet worden aangeboden, zoals bepaald per gemeente of regio. Producten die van dit symbool zijn voorzien, mogen niet samen met huishoudelijk afval worden verwijderd.
- DK** Dette symbol angiver, at i EU-lande skal dette produkt opsamles adskilt fra husholdningsaffald, som defineret i hver enkelt region. Produkter med dette symbol må ikke smides ud sammen med husholdningsaffald.
- NO** Dette symbolet indikerer at produktet må behandles som spesialavfall i EU-land, iht. til retningslinjer for den enkelte regionen, og ikke kastes sammen med vanlig husholdningsavfall. Produkter som er merket med dette symbolet, må ikke kastes sammen med vanlig husholdningsavfall.

- SE** Symbolen anger att i EU-länder måste den här produkten kasseras separat från hushållsavfall, i enlighet med varje regions bestämmelser. Produkter med den här symbolen får inte kasseras tillsammans med hushållsavfall.
- FI** Tämä merkintä ilmaisee, että tuote on EU-maissa kerättävä erillään kotitalousjätteistä kunkin alueen voimassa olevien määräysten mukaisesti. Tällä merkinnällä varustettuja tuotteita ei saa hävittää kotitalousjätteiden mukana.
- HU** Ez a szimbólum azt jelenti, hogy az Európai Unióban ezt a terméket a háztartási hulladéktól elkülönítve, az adott régióban érvényes szabályozás szerint kell gyűjteni. Az ezzel a szimbólummal ellátott termékeket nem szabad a háztartási hulladék közé dobni.
- PL** Symbol oznacza, że zgodnie z regulacjami w odpowiednim regionie, w krajach UE produktu nie należy wyrzucać z odpadami domowymi. Produktów opatrzonych tym symbolem nie można utylizować razem z odpadami domowymi.
- CZ** Tento symbol udává, že v zemích EU musí být tento výrobek sbírán odděleně od domácího odpadu, jak je určeno pro každý region. Výrobky nesoucí tento symbol se nesmí vyhadzovat spolu s domácím odpadem.
- SK** Tento symbol vyjadruje, že v krajinách EÚ sa musí zber tohto produktu vykonávať oddelene od domového odpadu, podľa nariadení platných v konkrétnej krajine. Produkty s týmto symbolom sa nesmú vyhadzovať spolu s domovým odpadom.
- EE** See sümbol näitab, et EL-i maades tuleb see toode olemprügist eraldi koguda, nii nagu on igas piirkonnas määratletud. Selle sümboliga märgitud tooteid ei tohi ära visata koos omeprügiga.
- LT** Šis simbolis rodo, kad ES šalyse šis produktas turi būti surenkamas atskirai nuo buitinių atliekų, kaip nustatyta kiekviename regione. Šiuo simboliu paženklinoti produktai neturi būti išmetami kartu su buitiniams atliekomis.
- LV** Šis simbols norāda, ka ES valstīs šo produktu jāievāc atsevišķi no mājsaimniecības atkritumiem, kā noteikts katrā reģionā. Produkts ar šo simbolu nedrīkst izmest kopā ar mājsaimniecības atkritumiem.
- SI** Ta simbol označuje, da je treba proizvod v državah EU zbirati ločeno od gospodinskih odpadkov, tako kot je določeno v vsaki regiji. Proizvoda s tem znakom ni dovoljeno odlagati skupaj z gospodinskimi odpadki.
- GR** Το σύμβολο αυτό υποδηλώνει ότι στις χώρες της Ε.Ε. το συγκεκριμένο προϊόν πρέπει να συλλέγεται χωριστά από τα υπόλοιπα οικιακά απορρίμματα, σύμφωνα με όσα προβλέπονται σε κάθε περιοχή. Τα προϊόντα που φέρουν το συγκεκριμένο σύμβολο δεν πρέπει να απορρίπτονται μαζί με τα οικιακά απορρίμματα.

For China

有关产品中所含有害物质的说明

本资料就本公司产品中所含的特定有害物质及其安全性予以说明。
本资料适用于2007年3月1日以后本公司所制造的产品。

环保使用期限



此标志适用于在中国国内销售的电子信息产品，表示环保使用期限的年数。所谓环保使用期限是指在自制造日起的规定期限内，产品中所含的有害物质不致引起环境污染，不会对人身、财产造成严重的不良影响。
环保使用期限仅在遵照产品使用说明书，正确使用产品的条件下才有效。
不当的使用，将会导致有害物质泄漏的危险。

产品中有毒物质的名称及含量

部件名称	有害物质					
	铅 (Pb)	汞 (Hg)	镉 (Cd)	六价铬 (Cr(VI))	多溴联苯 (PBB)	多溴二苯醚 (PBDE)
外壳(壳体)	×	○	○	○	○	○
电子部件(印刷电路板等)	×	○	×	○	○	○
附件(电源线、交流适配器等)	×	○	○	○	○	○

本表格依据SJ/T 11364的规定编制。

○：表示该有害物质在该部件所有均质材料中的含量均在GB/T 26572 规定的限量要求以下。
×：表示该有害物质至少在该部件的某一均质材料中的含量超出GB/T 26572的限量要求。
(企业可在此处，根据实际情况对上表中打“×”的技术原因进行进一步说明。)

For EU Countries

Manufacturer: Roland Corporation
2036-1 Nakagawa, Hosoe-cho, Kita-ku, Hamamatsu, Shizuoka 431-1304, JAPAN

Importer: Roland Corporation
ENA 23 Zone 1 nr. 1620 Klaus-Michael Kuehnelaan 13, 2440 Geel, BELGIUM



For the U.K.

Manufacturer: Roland Corporation
2036-1 Nakagawa, Hosoe-cho, Kita-ku, Hamamatsu, Shizuoka 431-1304, JAPAN

Importer: Roland Europe Group Limited
Hive 2, 1530 Arlington Business Park, Theale, Reading, Berkshire. RG7 4SA United Kingdom



Roland Service Centers and Distributors

When you need repair service, access this URL and find your nearest Roland Service Center or authorized Roland distributor in your country.

<https://roland.cm/service>

